



READY MEALS

INDUSTRY



*Meeting the Ready Meal packaging challenge
- The Bilwinco Way*

BILWINCO
www.bilwinco.com



AIRLINE MEALS

Anyone in the business of preparing ready meals for airlines knows how important flexibility, cleanability and quick product changeover times are – in this industry you often don't know at noon today what you will be packing early tomorrow morning. Further, the product placement accuracy is paramount here – the consumer expects authentic-looking meals! Bilwinco is *the* distribution tool expert – we tailor-make the distribution tools for your products so that you can be sure that the pasta is placed in the pasta compartment, the meat in the meat compartment etc.

We often build packing lines with mobile multihead weighers for the ready meal industry – these can be used more flexibly by moving the multihead weigher between several packing lines, and they can be taken offline for thorough cleaning jobs.

And speaking of cleaning, our Revolution Series multihead weighers set new hygiene standards in the multihead weigher business – our cleaning times are up to 50% shorter than our competitors' due to the sleek, cleaning-friendly design of our weighers. The whole weigher is waterproof to IP67 standards and can be high pressure cleaned. The accumulation and weighing hoppers are interchangeable, something that saves substantial amounts of time when disassembling for thorough cleansing.

Our direct weighing and self-taring weighing sensors show unmatched accuracy, and the Linear Drive radial feeders keep even difficult and sticky products moving at the optimum pace, maintaining your productivity regardless of the product being packed.

Examples of custom-built mobile Bilwinco distribution tools for the ready meals industry



Anyone can handle short pasta, but the longer the pasta is, the better the meal is. This is how the customer evaluates quality. Long fresh cooked pasta is a true multihead weigher challenge – but Bilwinco has found the way, with a patented rotating rim system. Combine this with our Linear Drive radial feeder vibration system and you get a solution that beats the accuracy of any other solution available, without compromising pasta quality

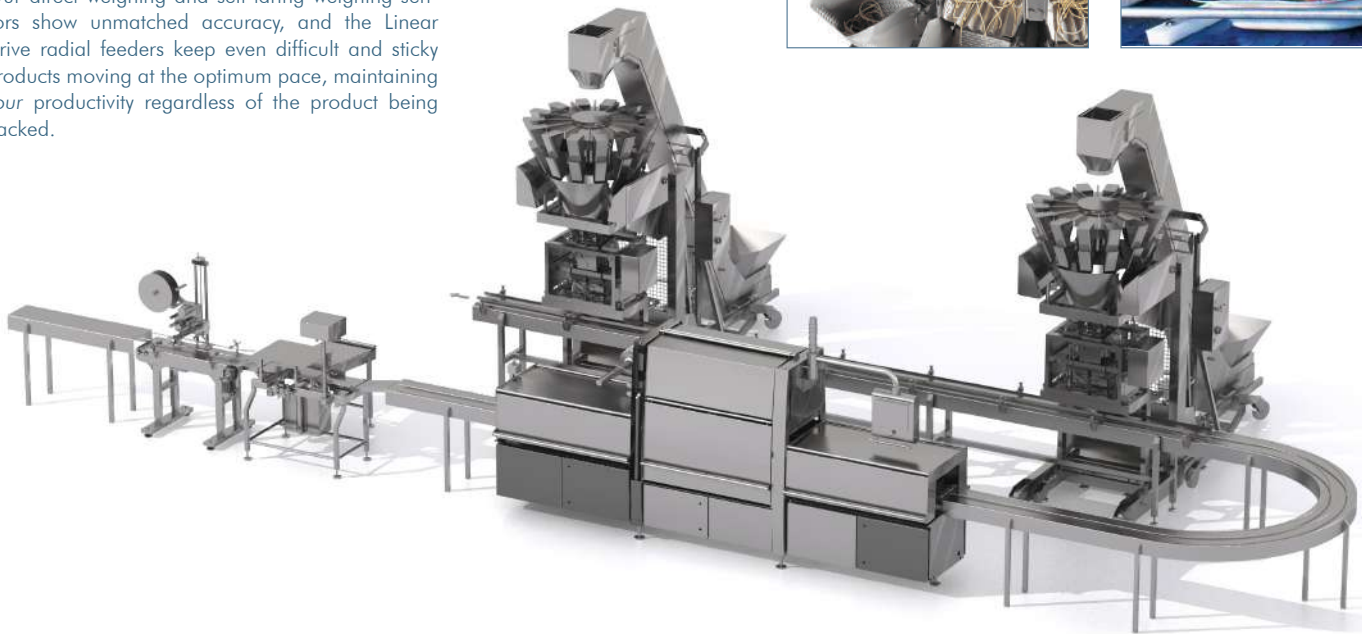

- 1) Mobile infeed conveyor with drop-down feature
- 2) Mobile multihead weigher
- 3) Mobile tray filling tool
- 4) Tray conveyors
- 5) Tray sealer
- 6) Check weigher
- 7) Labeller

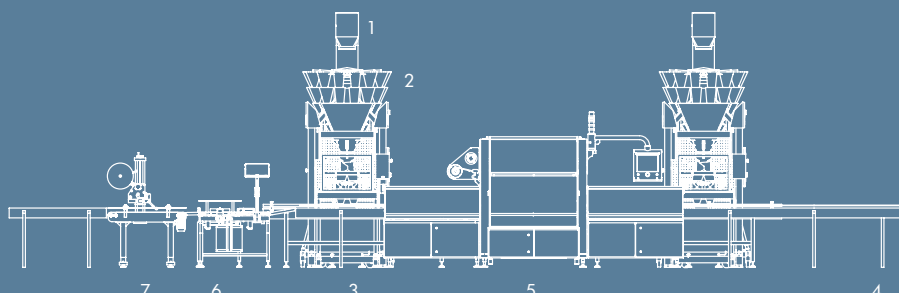

ASSEMBLED MEALS

The challenge with assembled meals is to make each dish look as if it were hand-assembled by white-clad chefs wearing toques – when in fact the meal is largely the result of an automated process, ideally untouched by human hands throughout. In order to meet the challenge, Bilwinco builds tailor-made distribution tools that ensure accurate product placement in the tray every time. As in the airline meals industry, mobile weighing units are often called for in order to maintain production flexibility, and the added benefit of the improved cleanability makes this the option of choice for many of our customers.

An assembled meal will often consist of elements that are easy to portion and weigh with a multi-head weigher, and elements that cause traditional weighers grief. These latter could be cooked fresh pasta, some meat dishes, marinated dishes etc. With the new Bilwinco Revolution Series multihead weighers, and their Linear Drive radial feeders, even very difficult products are processed trouble free and efficiently.

Cleanability is a keyword in the assembled meal industry – only with the most diligent hygiene standards can shelf life be ensured. Bilwinco makes staying clean easy, as our machines are the most cleaning-friendly weighers on the market – this translates into higher line availability for you, and ultimately better figures on the bottom line.



Many customers in the ready meals industry choose the mobile Bilwinco weighing solutions due to the extra flexibility and the improved cleanability of such a setup

Placement accuracy is critical in the ready meals industry. Bilwinco designs and builds custom-made distribution tools for each application, so that you can be sure that your ingredients are always placed where you want them

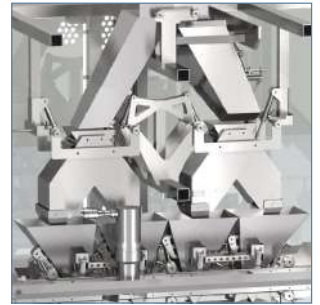

- 1) Infeed conveyor
- 2) Product guide
- 3) Multihead weigher
- 4) Tray denester
- 5) Continuous motion filling tool
- 6) Sauce dosing
- 7) Tray sealer

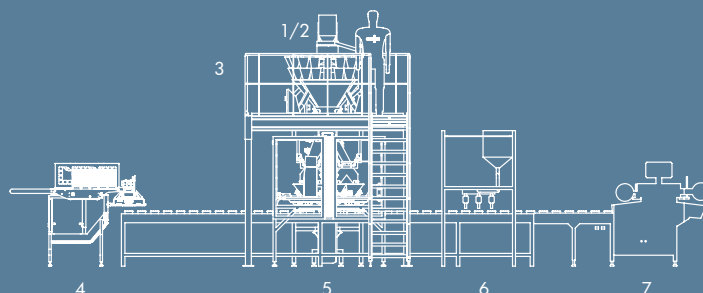

THE BILWINCO WAY

Bilwinco supplies complete packaging solutions for the Ready Meals industry. But we are more than a supplier of weighing and packaging solutions; we are your innovative business partner through every step of the process, from idea to operational packaging line.

Key arguments for a Bilwinco solution to your packaging needs:

- LESS GIVEAWAY – direct weighing ensures 20-30% less giveaway compared to traditional weighers
- HIGHER CONSTANT THROUGHPUT of difficult products with Linear Drive vibration (Patent pending), keeping productivity high and product quality unmatched
- LOWEST COST OF OWNERSHIP(COO) on the market



TURNKEY PACKAGING SOLUTIONS

Our packaging lines consist of a custom-built Bilwinco weighing line combined with the packaging solution of your choice. Our strength is our intimate knowledge of the packaging solutions out there, and how they interact with your product and our state-of-the-art multihead weighers. By choosing us as your turnkey contract supplier you eliminate many of the expensive variables inherent in the process. You define the task at hand once, to one partner, and we design the whole packaging line. Once the line is operational you have only one service number to call; ours.

OPERATIONALISING YOUR KNOWLEDGE

At the heart of the matter lies our conviction that you know your products, and your markets, better than anyone else. Our task is simple; we listen, we observe and then we operationalise your knowledge, by building packaging lines matching your expectations. We call it the Bilwinco way.

G R E A S Y
S T I C K Y
F R A G I L E

The weigher is the pivotal unit in the multihead weigher packaging line. The speed and efficiency of the weigher defines the gross output of the entire line – and we are multihead weigher experts! The Bilwinco Revolution multihead weigher series is state-of-the-art technology from start to finish and the only weigher that excels with difficult and fragile foodstuffs. Practical tests have shown gross productivity increases of up to 10-15% compared to our competitors when processing difficult products. The improvements are accomplished through refinements of every step of the operational process, not least the improved hygiene, which in itself amounts to up to 50% less downtime for cleaning during product changeovers – particularly important in hygiene-sensitive production such as the ready meal industry.



Bilwinco has been a market leader in the weighing and packaging industry since 1955. At our company headquarters in Skanderborg, Denmark, we develop and build individual solutions for our customers worldwide. Our experience is your guarantee that a Bilwinco packaging solution is always tailored to your particular demands.

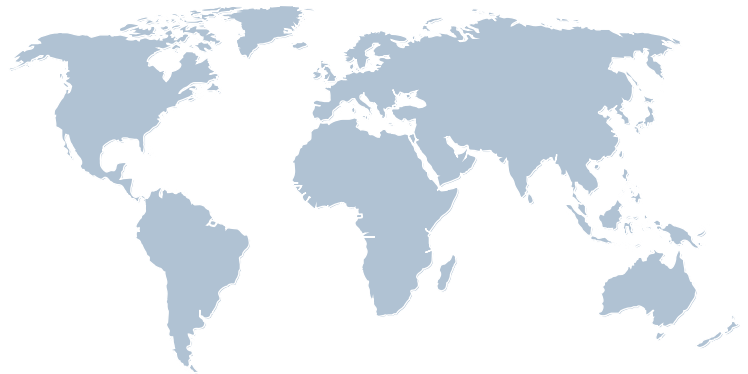

Contact us

At Bilwinco we have people specialised in packaging solutions for the Ready Meals industry. We are eager to begin the dialogue with you which will ultimately result in the perfect packaging line for your Ready Meal products. May we suggest that you give us a call!



BILWINCO A/S

Sverigesvej 9
P.O. Box 419
8660 Skanderborg
Denmark
Tel: +45 86 51 06 66
Fax: +45 86 51 06 11
Email: mail@bilwinco.com
www.bilwinco.com

