

- **LESS GIVEAWAY** – direct weighing ensures 20-30% less giveaway compared to traditional weighers
- **HIGHER CONSTANT THROUGHPUT** with HIGH POWER and SUPERB VIBRATION TECHNOLOGY you keep productivity high and you can handle products no-one else can.
- **LOWEST COST OF OWNERSHIP (COO)** on the market

YOUR PRODUCTIVITY IS OUR CONCERN

By completely rethinking the way we handle your product, from the product infeed over the centre cone and into the individual weigher heads we have accomplished nothing less than a performance leap in this crucial area. Our vibrator technology can be set to move almost any product carefully and efficiently, including difficult products such as wet, sticky/greasy and fragile products.

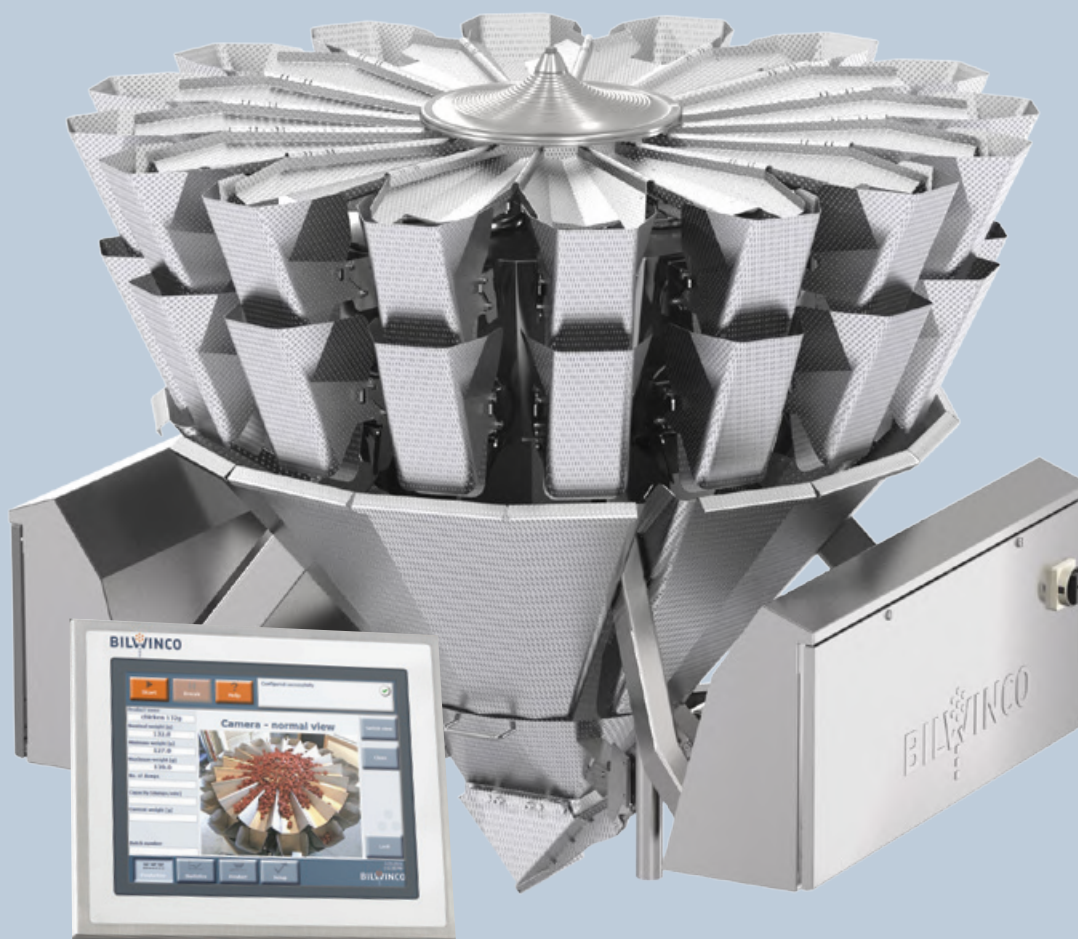

RW REVOLUTION WEIGHER

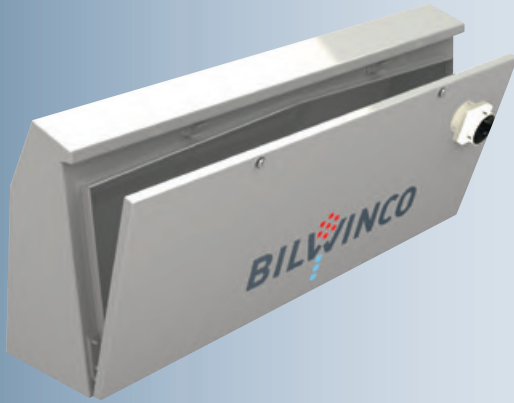

COMBINE UNIQUE DESIGN AND GREAT FUNCTIONALITY

Open just one hinged door and You have full access to the main scale control. Angled surfaces allow no water to stay or bacteria to grow. The most hygienic multihead on the market, of course also include hygienic waterproof cabinets. Even the inner extra rim behind the door, is angled for easily leading sanitation water away. A small detail, like the door closes protected UNDER an angled roof, makes a big difference in the daily sanitation process. The steep angles also ensures quicker and safer drying process.

BILWINCO - EASY OPERATION

The RW Revolution Series comes with the largest Touch Screen HMI on the market for Multihead Scales. The size makes it easy for the operators surveying the clear menus and operate the large buttons. The user-friendly 15" Screen features OEE readings (Operating Equipment Efficiency), Statistical data, Operator Settings and much more. Data is shown on-screen or sent to a USB stick or via Ethernet to other devices. Data can be displayed through performance graphs to help optimizing. Basically all historical data are logged. The control panel is cased in a smooth and easy to clean stainless steel IP65 rated frame, and for mounting in positions being

most convenient for the operators. A very nice optional feature is the operator-time-saving integrated survey cam, making it possible to survey the top of the multihead from floor level - and from there even direct the cam and zoom in if required.

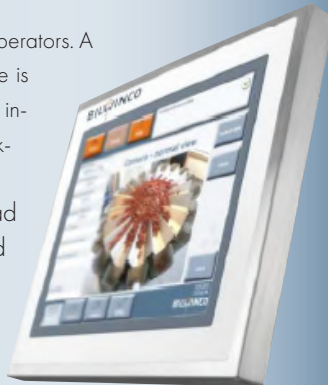

A VERY POWERFUL CENTREVIBRATOR

A key factory in high speed and accuracy, is the ability to transport the product perfectly. High power vibration by means of flexible vibration frequency and high or low amplitude, is a skill Bilwinco has been known for, as the best in the market, since 1955. Every machine leaving the factory has gone t a custom and product dependent routine, securing ideal amplitude and frequency for the specific product and project requirements.

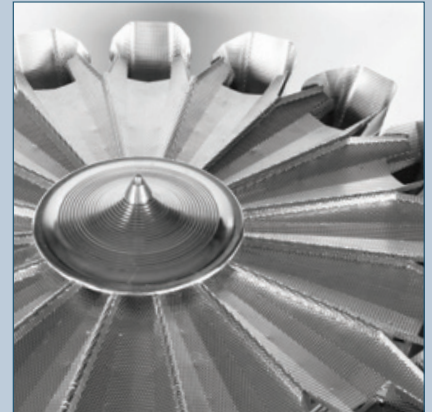

NOTHING BUT THE BEST LOADCELLS ON MARKET

Are of course to find on this unique machine. Overload protected, high speed, high resolution, direct weighing - even hygienic and round - are words belonging to the integrated Bilwinco Weighing Technology and it all ensures you the best and most reliable accuracy ever. Should you accidentally brake it, of course you should only replace the loadcell, and nothing else.

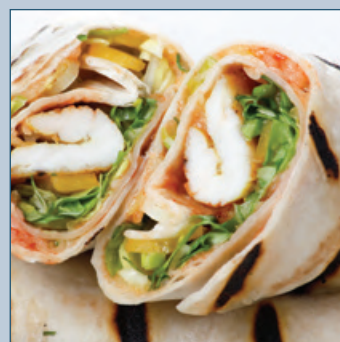

Water resistance is tested under extreme conditions for several hours of high pressure sanitation. The fully waterproof scale is guaranteed for several daily sanitations with up to 900 PSI (60 Bar) of direct high pressure water jet at 20"/500 mm. As part of the design phase, all gaskets are however tested positive at 120 bars (1800 PSI) of direct water jet at distances below 10"/250 mm.

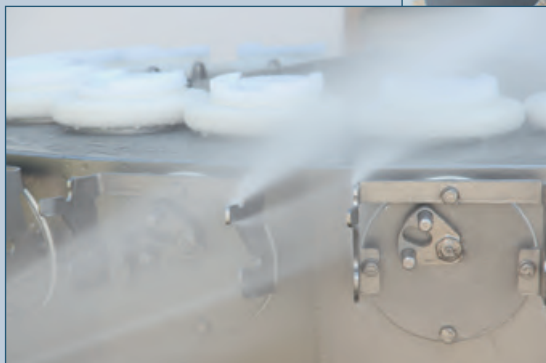

The actuators are turned and therefore offers a smoother surface. An angled top fully welded onto the sleek body, leads to no unhygienic edges or overlapping seams. Under the principle of "fix only what is broken", you can access or replace individual components. One actuator eg comes free by loosening just 4 bolts. This is part of the reason why this machine is the most economic machine to maintain on the market.



Every tiny detail has been carefully designed for highest level of hygienic design and best sanitation. The machine has gone thru and passed all of the toughest bacterial tests. As part of the tests, a handheld device scans for potential bacterial leftovers after sanitation.

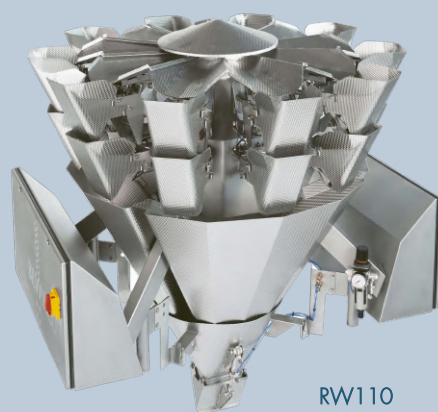

RW110

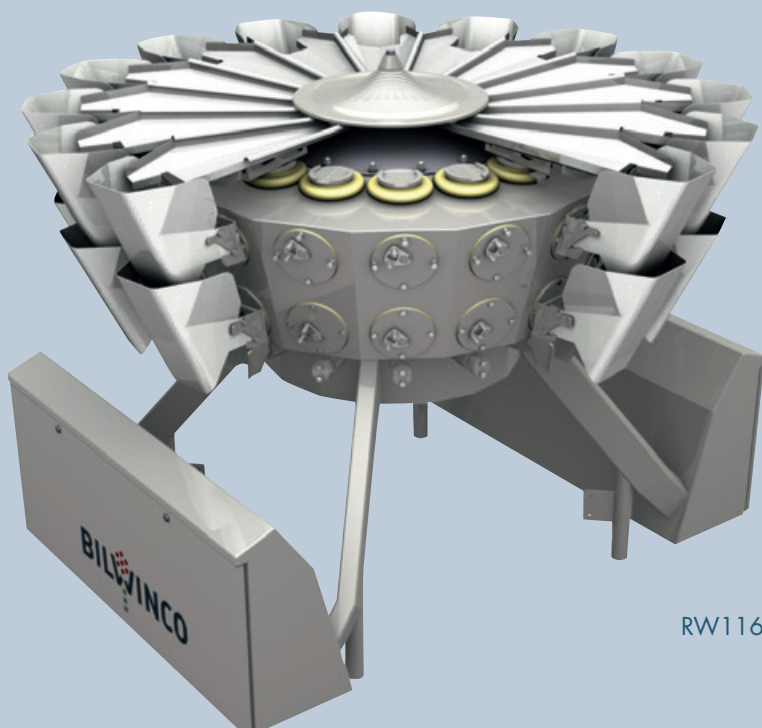

RW116

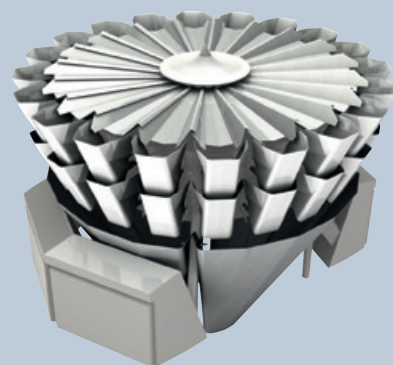

RW120

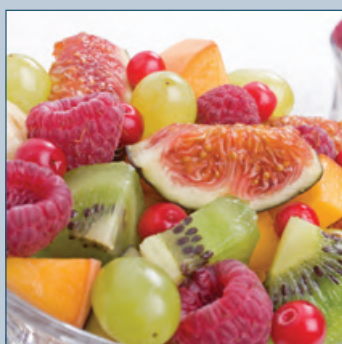

RW WET SERIES

Technical details

MODEL	RW110	RW112	RW116	RW120	RW212	RW216	RW220	RW316
Product Sizes (mm)	2-130	2-150	2-130	2-130	2-180	2-180	2-180	5-240
Bucket sizes (L)	1-2	1-2-3	1-2	1-2	5	5	5	10
Portion Volume (L)	3-4	3-8	3-5	3-5	3-20	3-20	3-20	5-35
Accuracy (g)	+/- 0,5-1	+/- 0,5-1	+/- 0,5-1	+/- 0,5-1	+/- 1-2	+/- 1-2	+/- 1-2	+/- 1-3
Capacity (ppm)	Up to 75	Up to 90	Up to 140	Up to 200	Up to 75	Up to 100	Up to 140	Up to 65
Dimensions (mm)	Ø 1394 H 1046	Ø 1457 H 1167	Ø 1494 H 1167	Ø 1664 H 1206	Ø 1895 H 1373	Ø 2083 H 1373	Ø 2409 H 1373	Ø 2439 H 1707
Weight (kg)	~375	~440	~540	~660	~860	~1150	~1433	~1335
High Power Vibrators	●	●	●	●	●	●	●	●
Linear Drive springless Vibrators	–	○	○	○	○	○	○	–
Pneumatic Actuators	●	●	●	●	●	●	●	●
Electrical Acutators	○	○	○	○	○	○	○	–

● Standard

○ Option

Since the leaflet was produced, both a RW114 and a RW124 edition have been developed, please contact our Sales Dept. for further details

We reserve the right to introduce design modifications without prior notice. Errors and omissions excepted.

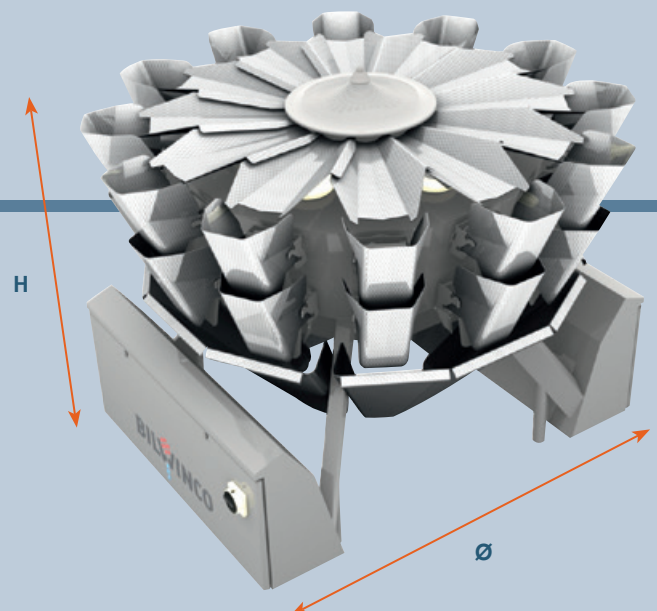

BILWINCO A/S
 Hedevej 3
 9800 Hjørring
 Denmark
 Tel: +45 86 51 06 66
 Email: info@bilwinco.com
 www.bilwinco.com