

AUTO-SHREDDER

SOLUTIONS



High Volume Shredding for
a "Hand-pulled" Look



MARLEN

A DURAVANT COMPANY

HIGH VOLUME SHREDDING

CONTINUOUS OPERATION PRODUCES A BROAD VARIETY OF COLD & HOT SHREDDED MEAT PRODUCTS WITH A “HAND-PULLED” LOOK

Our innovative and uniquely designed Auto-shredder is a continuous flow machine with throughput exceeding 2,000 pounds per hour. Engineered to easily break down tough products such as cooked beef logs with the same efficiency as it does softer products such as cooked chicken breast — the perfect shredding solution for mid- to large-sized processors.

ADVANTAGES OF MARLEN AUTO-SHREDDERS

DIRECT DRIVE FOR INCREASED EFFICIENCY AND LONGER LIFE.

All mechanisms (auger, main spindle, drum, pre-break, and shredding cage) function via the shredder’s direct drive for increased efficiency and a longer wear life. The Auto-shredder also utilizes an optional pre-break system that serves as both a product metering device and initial size reduction tool.

VARIABLE FREQUENCY DRIVE SPEED CONTROL FOR GREATER PRODUCT FLEXIBILITY.

A broader range of shredded meat types result from the ability to precisely control the speed of all the machine’s mechanisms.

FEATURES EASIER CLEANABILITY AND SUPERIOR HYGIENE.

A retractable drum, quick release radials and flight rods as well as a removable draft shaft and auger provide easy access to the machine’s components for improved sanitation and better hygiene. Constructed of stainless steel, the machine also features a number of angled surfaces and reduced hollow zones for improved water run off to prevent microbial buildup. We also offer a parts cleaning cart and incline conveyor, both engineered with ultra-hygienic features.

DELIVERS A BROAD VARIETY OF SHREDDED COOKED MEAT PRODUCTS

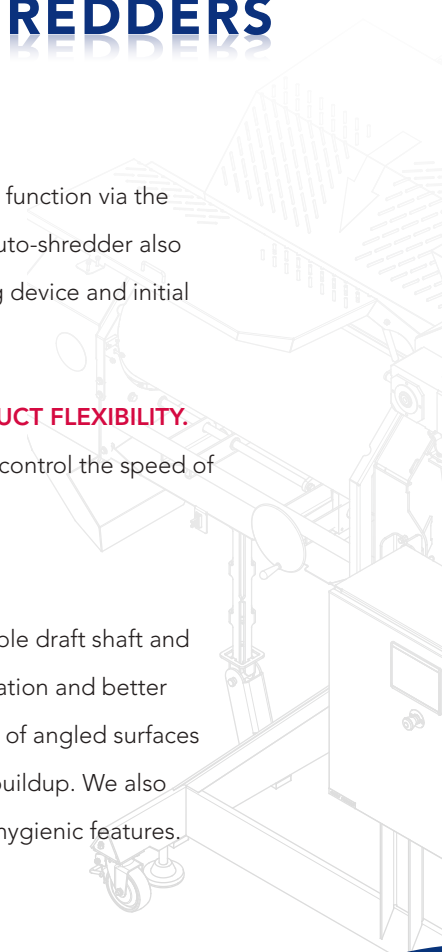



METHOD OF OPERATION

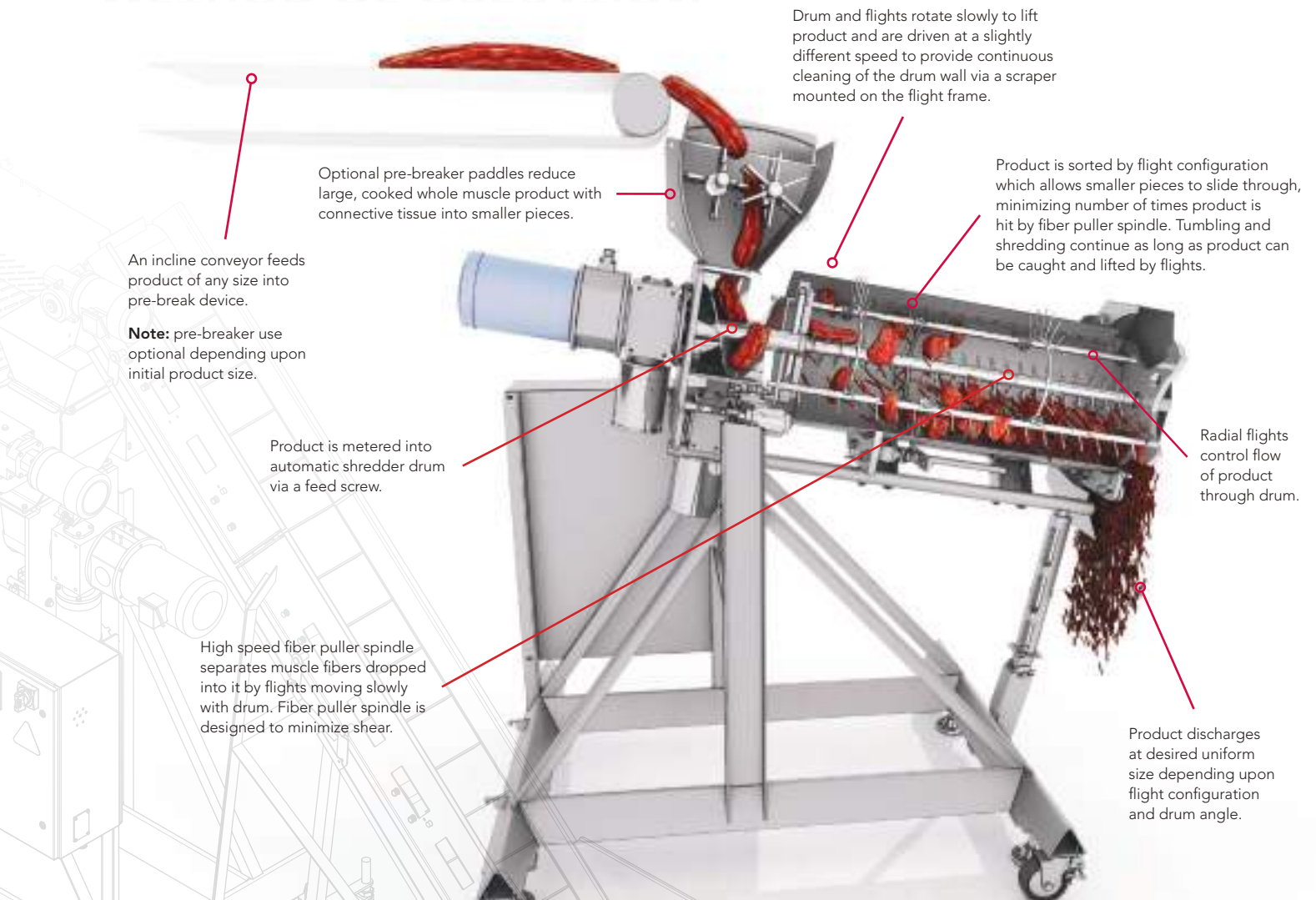

An incline conveyor feeds product of any size into pre-break device.

Note: pre-breaker use optional depending upon initial product size.

Optional pre-breaker paddles reduce large, cooked whole muscle product with connective tissue into smaller pieces.

Product is metered into automatic shredder drum via a feed screw.

High speed fiber puller spindle separates muscle fibers dropped into it by flights moving slowly with drum. Fiber puller spindle is designed to minimize shear.

Drum and flights rotate slowly to lift product and are driven at a slightly different speed to provide continuous cleaning of the drum wall via a scraper mounted on the flight frame.

Product is sorted by flight configuration which allows smaller pieces to slide through, minimizing number of times product is hit by fiber puller spindle. Tumbling and shredding continue as long as product can be caught and lifted by flights.

Radial flights control flow of product through drum.

Product discharges at desired uniform size depending upon flight configuration and drum angle.

COMMONLY SHREDDED COOKED MEATS:

Shredded Beef

- Chuck shoulder
- Boneless brisket
- Rib, blade meat
- Chuck rolls
- Beef round
- Flats
- Ball/Tri-tips
- Cooked beef rolls



Shredded Poultry

- Chicken breast
- Chicken thigh
- Spent chicken
- Hen meat
- Turkey breast
- Duck meats



Alternative Meats

- Jackfruit
- Textured vegetable protein (TVP)
- Mushrooms

Shredded Pork

- Picnic shoulder
- Boneless picnic
- Boston shoulder
- Bone-in/Boneless
- Shoulder butts
- Loin ends or hips (boneless)

NOTES:

- Product appearance can be controlled, from fine to coarse shredded meats.
- Optional CE compliant stainless cover available.
- Inquire about optimizing and shredding consistency of fully cooked chilled meat and poultry products.

TECHNICAL DIAGRAMS



FEATURE

TECHNICAL SPECIFICATIONS

MACHINE DIMENSIONS

Height	101 in. (2565 mm)
Width	55 in. (1397 mm)
Length	94 in. (2388 mm)

ELECTRICAL REQUIREMENTS

230/380/480 VAC; 50/60 Hz

18 Amps/30 Amps (with optional motors)

15 Amps/24 Amps (without optional motors)

MOTORS

Drive shaft	3-hp
Drum drive	1/2-hp
Auger drive	1-hp
Pre-break (optional)	1 1/2-hp
Conveyor (optional)	1/3-hp

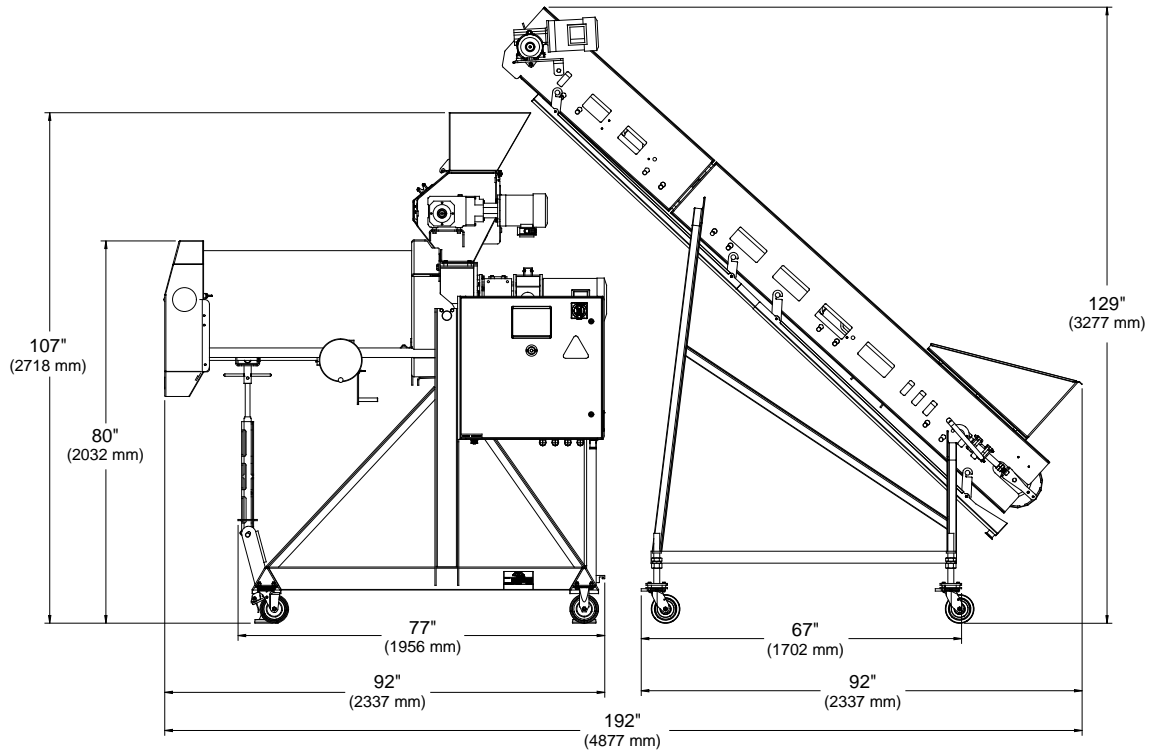
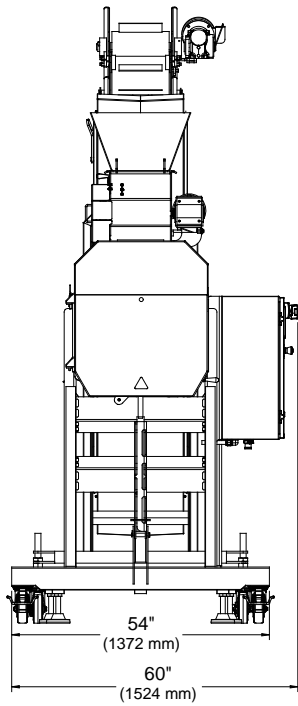

MARLEN

A DURAVANT COMPANY

4780 NW 41ST ST, STE. 100 • RIVERSIDE, MO 64150

TEL 913.888.3333 | TOLL FREE 800.862.7536 | FAX 913.888.6440 | EMAIL: SALES@MARLEN.COM | WWW.MARLEN.COM



MARLEN INTERNATIONAL IS A MEMBER OF THE DURAVANT FAMILY OF COMPANIES

www.duravant.com

FOOD PROCESSING SOLUTIONS | PACKAGING SOLUTIONS | MATERIAL HANDLING SOLUTIONS | SUPPORTPRO